

## Altech Smart Relay

Altech's Smart Relay comprises 2 base modules featuring an AC and DC version including 8 Inputs and 4 Relay Outputs. Each allows for up to 3 Expansion module to be connected for a maximum of 32 Inputs and 16 Outputs. Fast and easy setup and Programming is done thru a free software available for download from the Altech website. An additional Communication Modules allows communication with remote devices.



### Standards and Certifications

- UL 508
- IEC 61000-3-2
- IEC 61000-4-2-1~11

### Features

- Supports upto 48 I/Os (32 digital inputs & 16 digital outputs)
- DST Feature Available
- Backlit LCD Screen for display & modification of pre-selected parameters of functional blocks, viewing I/O status and programming on the device
- PC software for programming, online & offline simulation, documentation & printing
- Designed for use in automation for commercial & Industrial sectors
- Modbus Communication

### Programming Features

- 250 lines of ladder programming
- 16 soft text messages, Time Switches, Compare Counters, Timers, Counters & 12 analog functions

### Function Blocks

Timers:	16 (ON Delay, Interval, Cyclic ON-OFF, OFF Delay)
Counters:	16 (Up/Down, Retentive selectable)
Time Switches:	16 (Weekly / Daily)
Compare Counters:	16
Analog Functions:	12 (DC Model)
Soft Text Messages:	16 (Priority Driven)
Auxiliary Relays:	32



### Starter Kits



CAT. NO	ASR-B120AC-START	ASR-B24DC-START
Includes		
Base Module	ASR-B120AC	ASR-B24DC
Programming Software	ASR-SOFT	ASR-SOFT
Programming Cable	ASR-USB	ASR-USB

### FREE SOFTWARE DOWNLOAD

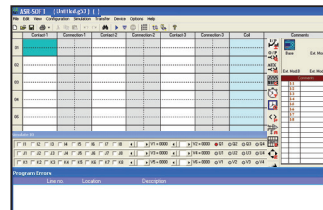

[AltechCorp.com/SmartRelay](http://AltechCorp.com/SmartRelay)

## Technical Specifications

<b>I/O Extensions (Max.)</b>	3
<b>Utilization Category</b>	<b>AC-15</b> Rated Voltage (Ue): 120/240 V, Rated Current (Ie): 3.0/1.5 A
	<b>DC-13</b> Rated Voltage (Ue): 24/125/250 V, Current (Ie): 2.0/0.22/0.1 A
<b>Power Reserve (For Clock Only)</b>	150h at -10°C to +55°C
<b>Operating Temperature</b>	-10°C to +55°C
<b>Storage Temperature</b>	-25°C to +70°C
<b>Humidity (Non Condensing)</b>	95% (Rh)
<b>Enclosure</b>	Flame Retardant UL 94-V0
<b>Mounting</b>	Base / DIN Rail
<b>Degree of Protection</b>	IP 20 for Terminals, IP 40 for Enclosure



Base Module



Expansion Module

## Base Module

CAT. NO	ASR-B120AC	ASR-B24DC
Supply Voltage (-20% to + 10%)	110-240 VAC (50/60Hz)	12-24 VDC
Power Consumption	5W	5W
Max. Supply current	36 mA	360 mA
Digital Inputs	8	6
Digital Input Range	(0-40VAC) OFF, (80-265VAC) ON	(0-4VDC) OFF, (8-26.4VDC) ON
Analog Inputs	N/A	2 (can be used as Digital Inputs)
Analog Input Range	N/A	0 to 10 VDC
Digital Relay Output	4 NO (8A@240V AC, 5A@30V DC)	4 NO (8A@240V AC, 5A@30V DC)
Weight	0.51 lb. (230 g)	0.51 lb. (230 g)

## Expansion Module

CAT. NO	ASR-E120AC	ASR-E24DC
Digital Inputs	8	6
Digital Input Range	(0-40VAC) OFF, (80-265VAC) ON	(0-4VDC) OFF, (8-26.4VDC) ON
Analog Inputs	N/A	2 (can be used as Digital Inputs)
Analog Input Range	NA	0 to 10 VDC
Digital Relay Output	4 NO (8A@240V AC, 5A@30V DC)	4 NO (8A@240V AC, 5A@30V DC)
Weight	0.5 lb. (225 g)	0.5 lb. (225 g)

## RS485 Communication Module (including communication cable)

<b>Input</b>	TTL Level
<b>Output</b>	RS-485 protocol (two wires, D+, D-)
<b>Number of Nodes</b>	32 standard unit loads
<b>Isolation Voltage</b>	2000 Vrms
<b>Baud Rate</b>	300, 600, 1200, 2400, 4800, 9600
<b>Operating temperature</b>	-10°C to +55°C
<b>Storage temperature</b>	-20°C to +70°C
<b>LED Indicators</b>	Red LED's for Tx & Rx. Green LED for Power indication
<b>Weight</b>	0.19 lb. (84 g)



Communication Cable

CAT. NO	ASR-C485-120AC	ASR-C485-24DC
Supply Voltage	110-240 VAC	12-24 VDC
Weight	0.18 lb. (80 g)	0.19 lb. (84 g)

## Software & Accessories



CAT. NO	ASR-SOFT	ASR-MC	ASR-USB	ASR-RS232
	Programming Software	Memory Card	USB Cable	Serial RS232 Cable

SUPPLY, INPUT & OUTPUT CONNECTIONS

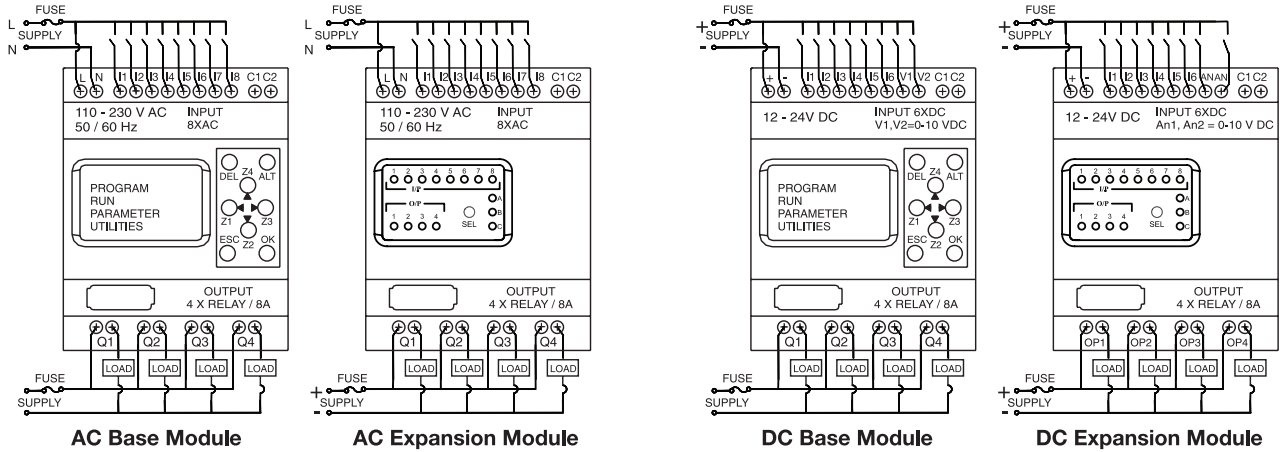

Fig. 1

Fig. 2

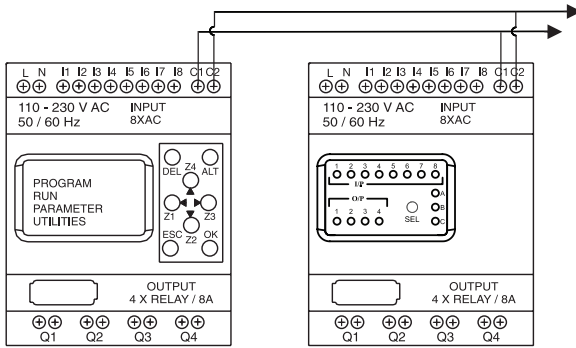

Fig. 3

Connection Between Base Module & Expansion

Same for both AC & DC

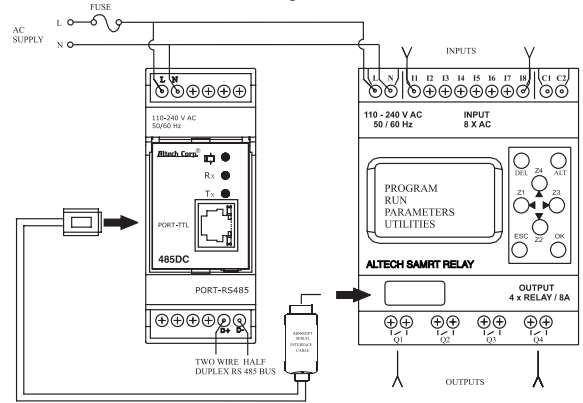

Fig. 4

Connection Between Base Module & Communication Module

Power Supply Wiring

1. Although the Altech Smart Relay has been designed to withstand the negative effects of any electrical noise that might be present its power supply. It may be necessary to insert an isolation transformer between the supply and line terminals of the Altech Smart Relay.
2. While using the DC Altech Smart Relay, run the 24 VDC Input line separate from 100 ~240V AC power lines.

Wiring of Input/Output

1. Separate input and output lines.
2. When the output lines are running close to power supply or input lines, use shielded wires and ground them.

Mounting Dimensions

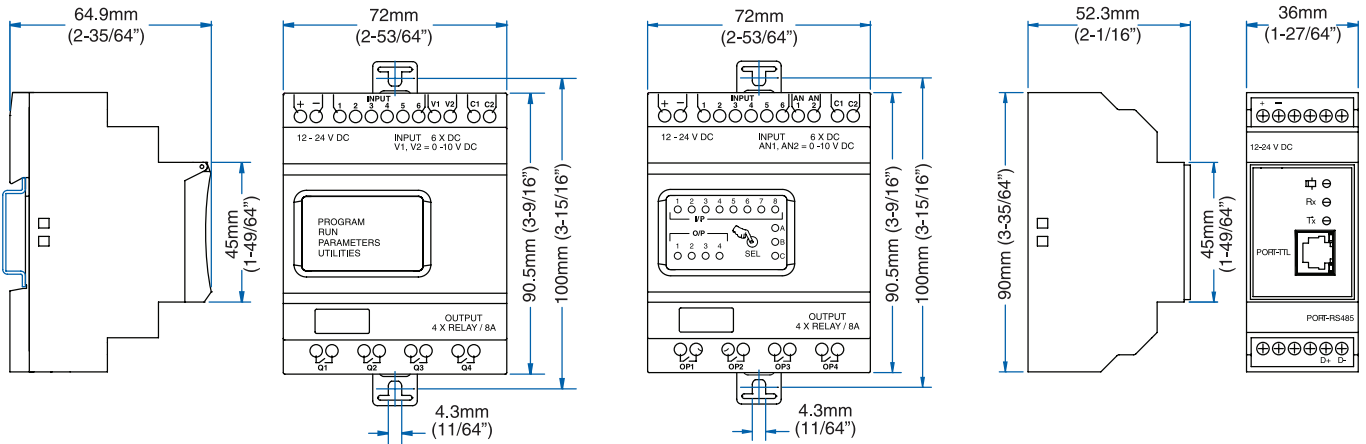

Programmable Smart Relay Base Module

Programmable Smart Relay Expansion Module

Programmable Smart Relay Communication Module